

UTP VDS REMOTE LONG RANGE UNIT

QUICK INSTALLATION GUIDE

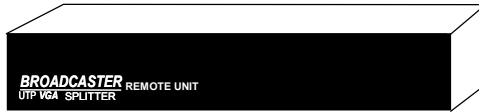

www.minicomdigitalsignage.com

International HQ

Dübendorf, Switzerland
Tel: +41 44 823 8000
ds@minicom.com

North American HQ

Linden, NJ, USA
Tel: + 1 908 486 2100
ds.usa@minicom.com

European HQ

Dübendorf, Switzerland
Tel: + 41 44 823 8000
ds.europe@minicom.com

Technical support - ds.support@minicom.com

SUM40182 V1.1 2/09

1. The Remote Long Range Unit

The figure below illustrates Remote Long Range Unit front panel.



The figure below illustrates the ports on the Remote Long Range Unit rear panel.

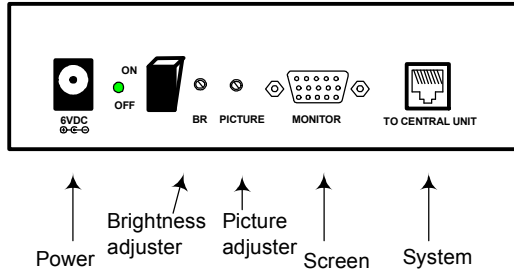

2. Connecting a monitor

Connect the monitor's connector to the Remote Long Range, Monitor port.

3. Connecting to the VDS system

Connect the To Central Unit port of the Remote Long Range to a VDS Broadcaster, System port, or to a VDS Line Splitter, System Out port using a CAT5 cable. See figure below.

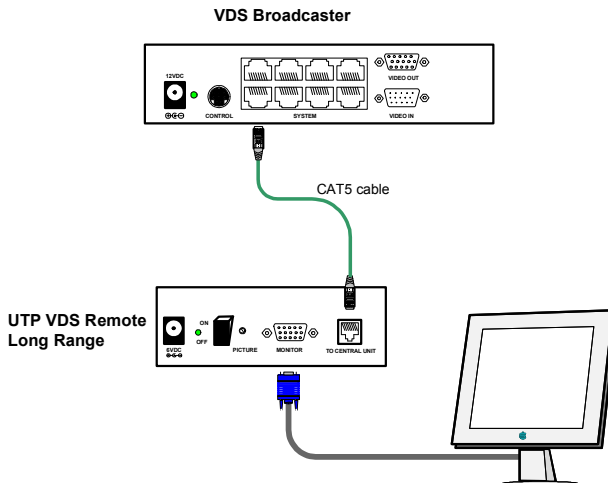

4. Connecting to the power supply

The Remote Long Range unit comes with a 6 VDC, 2A power adapter.

Connect each unit to the power supply with the Power adapter and cord provided.

5. How to set the dipswitches

The figure below illustrates the underside panel of the Remote Long Range unit, with 3 sets of dipswitches. The dipswitches are used for RGB compensation.

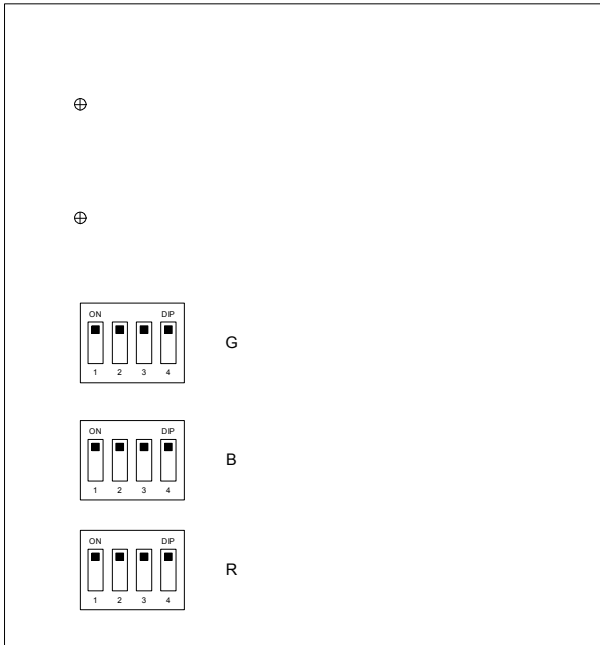

Setting the dipswitches

All 3 sets of dipswitches must have the same settings.

Set dipswitches 1 – 3 of each set according to the cable length, screen resolution and refresh rates. See the table below.

Note! Dipswitch number 4 is not used.

Cable Length		Screen Resolution and Refresh Rates			
M	ft	640x480 75 Hz	800x600 75 Hz	1024x768 75 Hz	1280x1024 75 Hz
50	165	ON OFF <input type="checkbox"/> <input type="checkbox"/> <input type="checkbox"/> 1 2 3	ON OFF <input type="checkbox"/> <input type="checkbox"/> <input type="checkbox"/> 1 2 3	ON OFF <input type="checkbox"/> <input type="checkbox"/> <input type="checkbox"/> 1 2 3	ON OFF <input type="checkbox"/> <input type="checkbox"/> <input type="checkbox"/> 1 2 3
100	330	ON <input type="checkbox"/> OFF <input type="checkbox"/> <input type="checkbox"/> <input type="checkbox"/> 1 2 3	ON <input type="checkbox"/> OFF <input type="checkbox"/> <input type="checkbox"/> <input type="checkbox"/> 1 2 3	ON <input type="checkbox"/> OFF <input type="checkbox"/> <input type="checkbox"/> <input type="checkbox"/> 1 2 3	ON <input type="checkbox"/> OFF <input type="checkbox"/> <input type="checkbox"/> <input type="checkbox"/> 1 2 3
150	490	ON <input type="checkbox"/> OFF <input type="checkbox"/> <input type="checkbox"/> <input type="checkbox"/> 1 2 3	ON <input type="checkbox"/> OFF <input type="checkbox"/> <input type="checkbox"/> <input type="checkbox"/> 1 2 3	ON <input type="checkbox"/> OFF <input type="checkbox"/> <input type="checkbox"/> <input type="checkbox"/> 1 2 3	ON <input type="checkbox"/> OFF <input type="checkbox"/> <input type="checkbox"/> <input type="checkbox"/> 1 2 3
200	650	ON <input type="checkbox"/> OFF <input type="checkbox"/> <input type="checkbox"/> <input type="checkbox"/> 1 2 3	ON <input type="checkbox"/> OFF <input type="checkbox"/> <input type="checkbox"/> <input type="checkbox"/> 1 2 3	ON <input type="checkbox"/> OFF <input type="checkbox"/> <input type="checkbox"/> <input type="checkbox"/> 1 2 3	ON <input type="checkbox"/> OFF <input type="checkbox"/> <input type="checkbox"/> <input type="checkbox"/> 1 2 3
250	820	ON <input type="checkbox"/> <input type="checkbox"/> OFF <input type="checkbox"/> <input type="checkbox"/> <input type="checkbox"/> 1 2 3	ON <input type="checkbox"/> <input type="checkbox"/> OFF <input type="checkbox"/> <input type="checkbox"/> <input type="checkbox"/> 1 2 3	ON <input type="checkbox"/> <input type="checkbox"/> OFF <input type="checkbox"/> <input type="checkbox"/> <input type="checkbox"/> 1 2 3	ON <input type="checkbox"/> <input type="checkbox"/> OFF <input type="checkbox"/> <input type="checkbox"/> <input type="checkbox"/> 1 2 3